



**ACME MANUFACTURING CORP.**

6532 TOWER LANE, CLAREMORE, OK. 74019

ENGINEERED PRODUCTS BY CRAFTSMEN

## Metal Roof Curb Welded Clip Type MRWC

### STANDARD FEATURES

Factory welded water tight rib pockets. Curb position relative to roof ribs **MUST** be determined prior to order.

Constructed of 18 ga. galv. steel with continuous welded seams and integral base plate for water tight construction and extra strength.

3½" wide base flashing on sides to cover roof panel.

Upper flashing is 8" wide with cricket style water diverter welded to base.

Lined with 1½" fiberglass fire proof sound attenuating thermal insulation.

Top ledge covered with ¼" polystyrene gasket for weather seal and to reduce metal to metal conducted noise.

Minimum curb height is 8" on the shortest vertical height.

### OPTIONS

- Constructed of 18 ga. galvalume steel or .063 aluminum.
- Interior metal liner.
- Standard heights of 12, 14, 16, 18, 20, 24", or any special height.
- Damper shelf – standard or custom size opening.
- Back draft damper; Damper motor, 120, 240, or 480 vac.
- Security bars.
- Protective or decorative coatings.

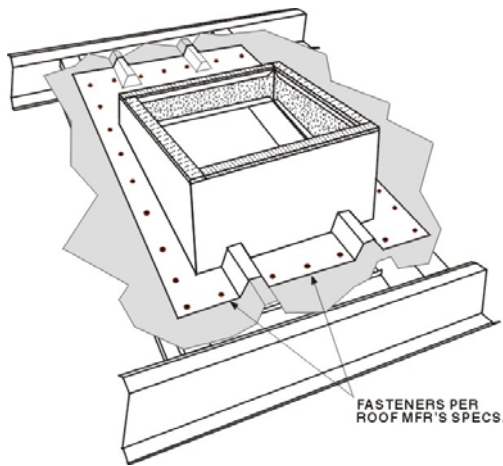

PROJECT	
LOCATION	
ARCHITECT	
ENGINEER	
CONTRACTOR	
SUBMITTED BY	
DATE	PO#

**THIS CURB IS DESIGNED FOR  
INSTALLATION ON TOP OF THE ROOFING.**

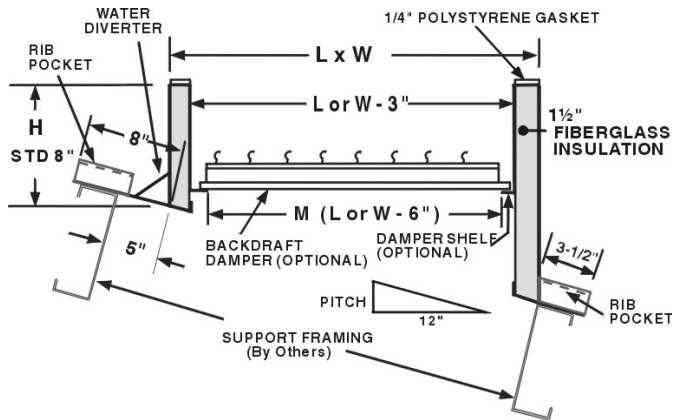

Damper shelf supported from top ledge of curb, but supported from base of curb when total rise over length > 2".

### SPECIFICATIONS AND DIMENSIONS

REFERENCE	QUAN.	L (Pitch Side)	W	H	PITCH	OPTIONS