



ACME MANUFACTURING CORP.

6532 TOWER LANE, CLAREMORE, OK. 74019

ENGINEERED PRODUCTS BY CRAFTSMEN

Pipe Curb Collar Type PCC

STANDARD FEATURES

Constructed of 18 ga. galv. steel with continuous welded seams and integral base plate for water tightness and extra strength.

Lined with 1½" fiberglass fire proof sound attenuating thermal insulation.

2 x 2 treated wood nailer.

Galvanized flashing cap with hole and welded collar for pipe.

Uses SF or RF curb. Curb style must be specified.

OPTIONS

- Constructed of .063" aluminum.
- Interior metal liner.
- Heights of 8, 14, 16, 18, 20, 24".
- Heavy-gage construction.

PROJECT	
LOCATION	
ARCHITECT	
ENGINEER	
CONTRACTOR	
SUBMITTED BY	
DATE	PO#

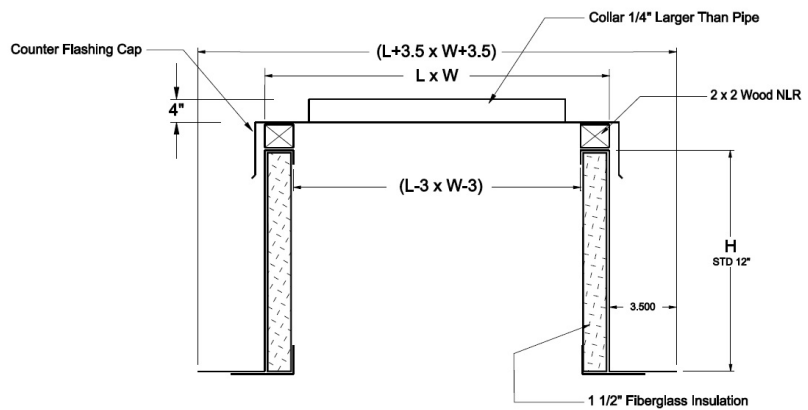

SPECIFICATIONS AND DIMENSIONS

REFERENCE	QUAN.	O.D. CURB	PIPE SIZE	CURB TYPE	H	OPTIONS