



**ACME MANUFACTURING CORP.**  
6532 TOWER LANE, CLAREMORE, OK. 74019

ENGINEERED PRODUCTS BY CRAFTSMEN

## Curb Adapter - Enlarger Type CAE

### STANDARD FEATURES

Constructed of 18 ga. galv. steel with continuous welded seams for water tightness and extra strength.

1/4" polystyrene gasket around top perimeter for weather seal.

### OPTIONS

- Constructed of .063" aluminum.
- Heavy gage construction.
- Decorative or protective coatings.

PROJECT	
LOCATION	
ARCHITECT	
ENGINEER	
CONTRACTOR	
SUBMITTED BY	
DATE	PO#

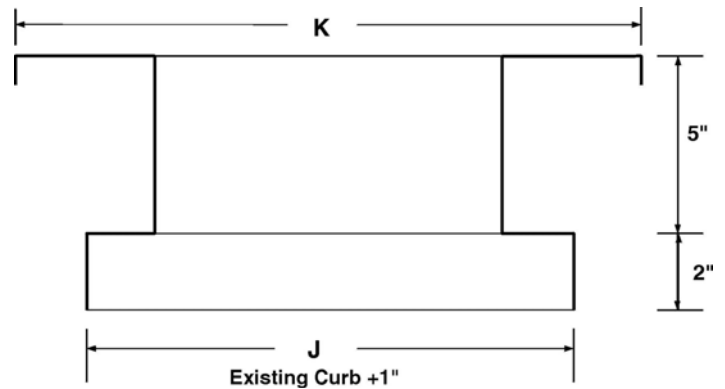
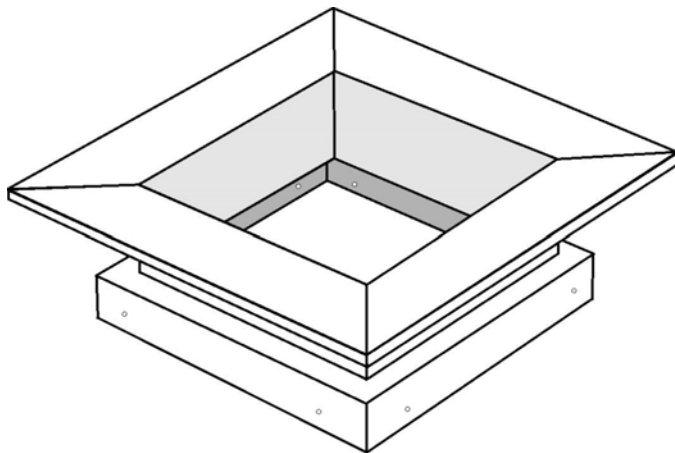

### SPECIFICATIONS AND DIMENSIONS

REFERENCE	QUAN.	K	J	OPTIONS