



ACME MANUFACTURING CORP.
6532 TOWER LANE, CLAREMORE, OK. 74019

ENGINEERED PRODUCTS BY CRAFTSMEN

Special Restaurant Curbs Self-Flashing Type Type SFR

STANDARD FEATURES

Constructed of 18 ga. galv. steel with continuous welded seams and integral base plate for water tightness and extra strength.

Wide base flashing to insure adequate bond to roofing surface for water tight seal to roof.

Insulation not furnished when curb is equipped with special ventilation slots.

Top ledge covered with ¼ " polystyrene gasket for weather seal and to reduce metal to metal conducted noise.

Minimum height is 18" to comply with NFPA Bulletin 96

OPTIONS

- Constructed of .063 aluminum.
- Interior metal liner.
- 1½ " fiberglass insulation (not available if sides vented).
- Optional 4" x ½" vent louvers – 1 to 4 sides.
- Any height.
- Protective or decorative coatings.
- Heavy-gage construction.

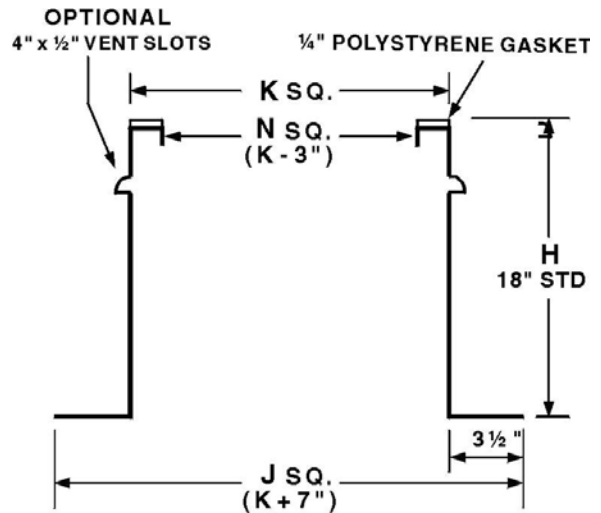
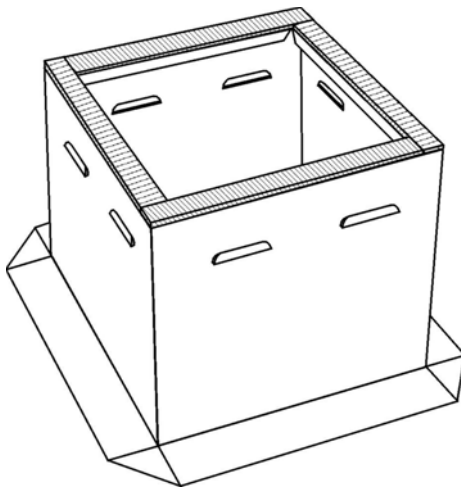

PROJECT	
LOCATION	
ARCHITECT	
ENGINEER	
CONTRACTOR	
SUBMITTED BY	
DATE	PO#

SPECIFICATIONS AND DIMENSIONS

REFERENCE	QUAN.	MAT'L	K	N	H	OPTIONS